

Name _____

Date _____

1. Find the total volume of the figures, and record your solution strategy.

a.

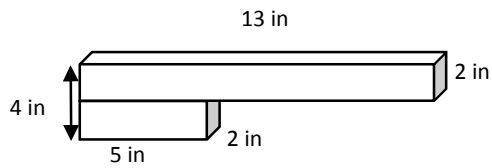

Volume: _____

Solution Strategy:

b.

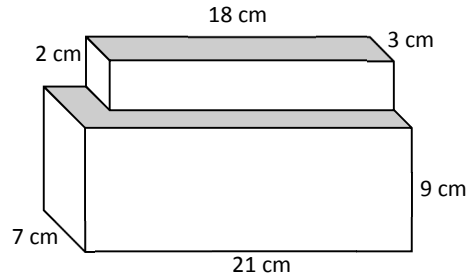

Volume: _____

Solution Strategy:

c.

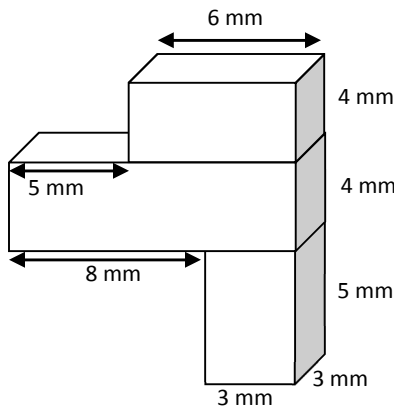

Volume: _____

Solution Strategy:

d.

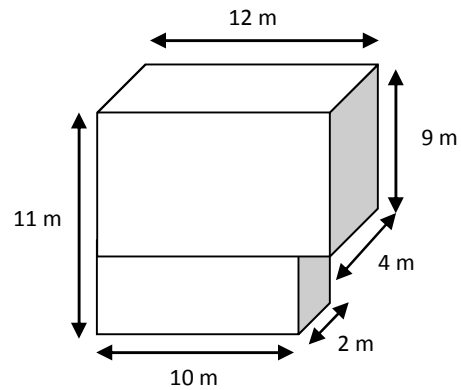

Volume: _____

Solution Strategy:

2. The figure below is made of two sizes of rectangular prisms. One type of prism measures 3 inches by 6 inches by 14 inches. The other type measures 15 inches by 5 inches by 10 inches. What is the total volume of this figure?
3. The combined volume of two identical cubes is 250 cubic centimeters. What is the measure of one cube's edge?
4. A fish tank has a base area of 45 cm^2 and is filled with water to a depth of 12 cm. If the height of the tank is 25 cm, how much more water will be needed to fill the tank to the brim?
5. Three rectangular prisms have a combined volume of 518 cubic feet. Prism A has one-third the volume of Prism B, and Prisms B and C have equal volume. What is the volume of each prism?